

MAINTENANCE :

The rope body of your Captains Chair is hand woven. If the weave of the rope body is pulled out of shape, you can brush or adjust it into shape with your hands. The wood frame should be periodically refinished using a high quality polyurethane varnish. When refinishing the wood, you have two options. First, you can remove the small wooden strips on the front and back of the chair, slide the rope body to one side, and apply varnish. After the finish has dried, slide the ropes to the other side and repeat. If you want to completely remove the ropes, take the following steps to keep the seat from coming unwoven. **Before removing the ropes from the wooden bars, slide guide ropes through the topmost and bottommost row of loops, and tie them off.** You can now safely remove all nuts and bolts from the wood using a 7/16 ratchet and key. Once all hardware is removed and safely stored, sand the wood using 120-grit sandpaper. You can use any shade of marine-grade polyurethane. We originally applied three coats of high-gloss varnish, but two coats should be sufficient. In between coats, lightly re-sand the wood pieces with 220-grit sandpaper after the wood has air-dried for 24 hours. Refinishing is the perfect time to also replace the nuts, bolts, washers, and screws, all readily available at your local hardware store.

To wash the rope seat, you can either leave the ropes attached to the chair or remove them. **If you remove the ropes, make sure you follow the instructions above to keep your seat from unravelling.** You will need OxiClean or laundry detergent and a soft scrub brush. To begin cleaning, wet the rope and apply the detergent. Additionally, you may use a very mild bleach solution, but be sure to rinse the ropes thoroughly afterwards. Take a handful of rope in each hand and rub the pieces together; using the soft-bristled scrub brush to work on any stains. Once you've cleaned all of the rope, rinse it thoroughly. If you have removed the rope from the chair, arrange it on a flat surface to air-dry so that the rope does not stretch.

If you have any questions about maintaining your chair, please give us a call at 1-800-344-6433 or 252-441-6115

WARRANTY AND RETURNS :

Nags Head Hammocks products are guaranteed to be free of defects in both workmanship and material. Prolonged exposure to weather conditions including snow, rain, and humidity are not covered under the warranty, nor is damage caused by normal wear, mildew, or improper care, including storage, maintenance, and assembly. If you are not satisfied with an item, return it unused in its original packaging for a complete refund or exchange. You can return it to any of our stores or to our warehouse, Nags Head Hammocks, 305 Industrial Blvd., Greenville, NC 27834. Please include a copy of your receipt and your contact information.

Instruction #: 5086NH, 0G.11

CAPTAINS CHAIR



Congratulations! You now own a Captains Chair that was handcrafted in North Carolina by Nags Head Hammocks. We hope you will have many years of comfort and enjoyment. If you have any questions, please feel free to contact us. Relax! It's a Nags Head Hammock original.

P.O. Box 533
Nags Head, NC 27959
1-800-344-6433 • 252-441-6115
www.nagshead.com

PARTS LIST :



1 Pre-Assembled Chair Body



1 Loose Oak Bar

1 Hardware Pack:

- (4) 3" Carriage Bolts
- (4) Galvanized Washers
- (4) Galvanized Lock Washers
- (4) Galvanized Nuts
- (2) 1.75" Stainless Steel Hex Bolts
- (4) Stainless Steel Washers
- (2) Stainless Steel Lock Nuts

Tips for Assembly :

- Tip 1: Do not tighten bolts completely until fully assembled
- Tip 2: For a more uniform look, face all bolts in the same direction

You Will Need : One 7/16" wrench and a mallet or hammer

ASSEMBLY :

Step 1 : Remove all pieces from the box and lay the pre-assembled chair body on the floor with the roll of netting facing up.

Step 2 : Pull the verticle supports upwards and place the adjustable brace bar into the fixed position between the two spacer bars attached to the back legs (see photo).

Step 3 : Untie the arm units from the vertical supports and rotate them until the tops of the arm rests are parallel to the floor (see photo).

Step 4 : Untie the netted roll-up. Unroll and remove the loose branded bar.



ASSEMBLY (CONTINUED) :

Step 5 : Attach the top bar of the roll-up to the top of the vertical supports using the 3" carriage bolts. The vertical supports will fit into the grooves in the roll-up bar. Loosely secure with galvanized washers, lockwashers, and nuts.

Step 6 : Attach arm units to the metal bracket located at the front of the chair using the 1.75" stainless steel hex bolts and stainless steel washers. The stainless steel nuts should be located on the outside of the chair (See Diagram).

ARM UNIT FRONT VIEW

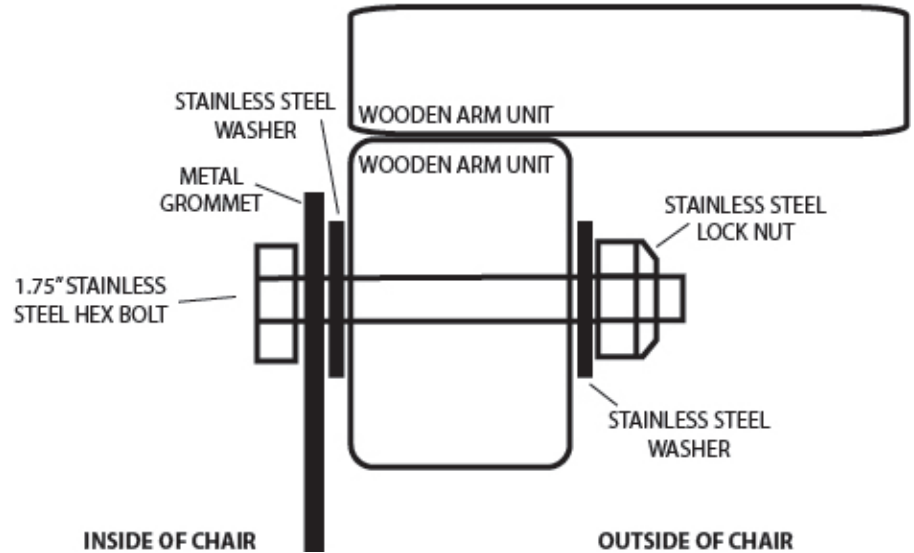

Step 8 : Attach the loose oak bar to the legs at front of the chair using the remaining 3" carriage bolts. Make sure the brand faces forward. Secure with galvanized washers, lockwashers, and nuts.

Step 9 : Tighten all hardware.

SEAT ADJUSTMENT :

You can easily adjust the angle of your chair by changing the position of the adjustable brace bar. The brace bar is designed to rest either between the two spacer bars for a more reclined seat, or on top of the higher bar, for a more upright sitting position. If the chair will not adjust, your hardware may be too tight. Try slightly adjusting the nuts that attach the legs and the arms of the chair.